

Forma 5

TECHNICAL FEATURES

M10



For anti-electrostatic solutions, please ask us the conditions.

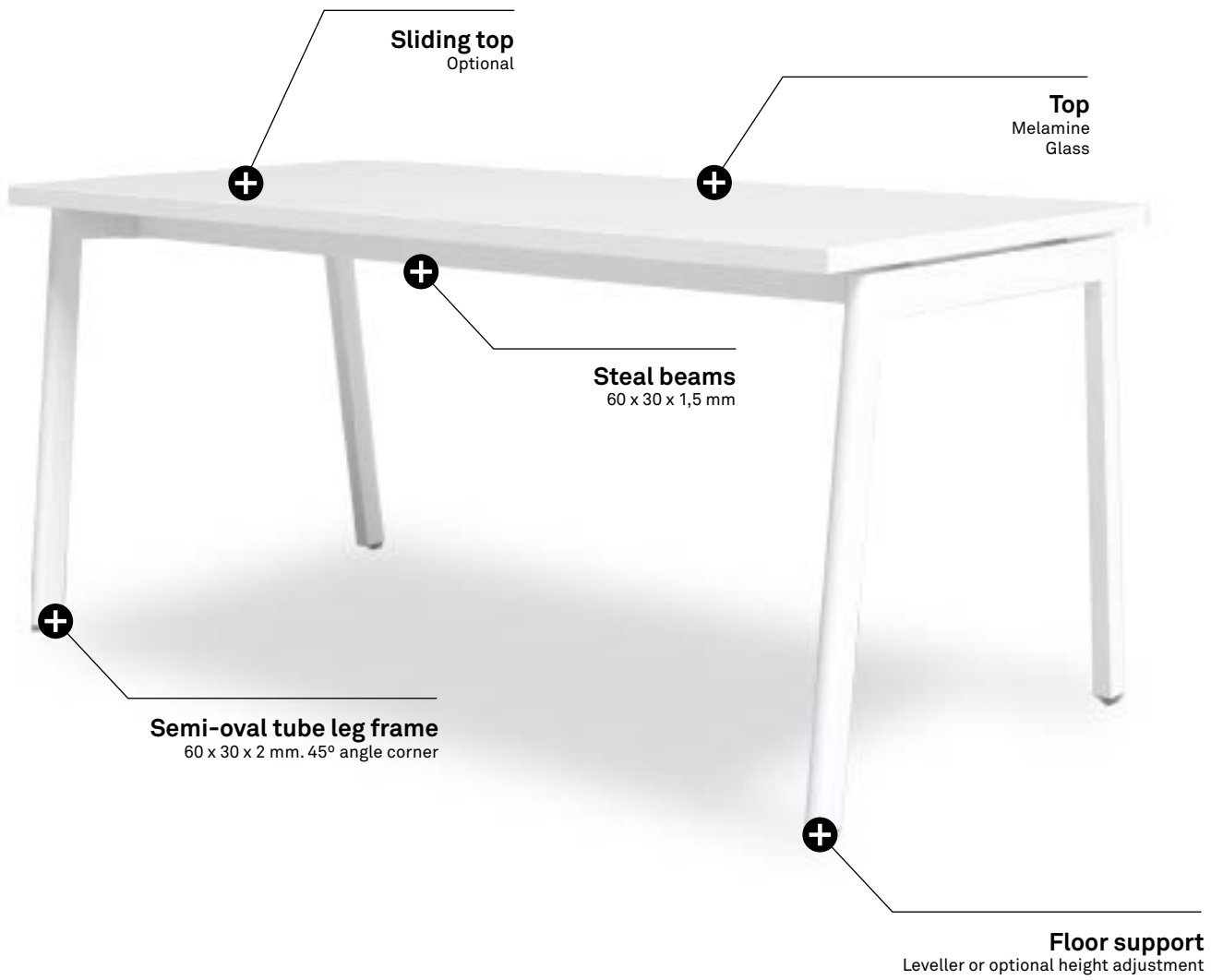

BENCH DESK

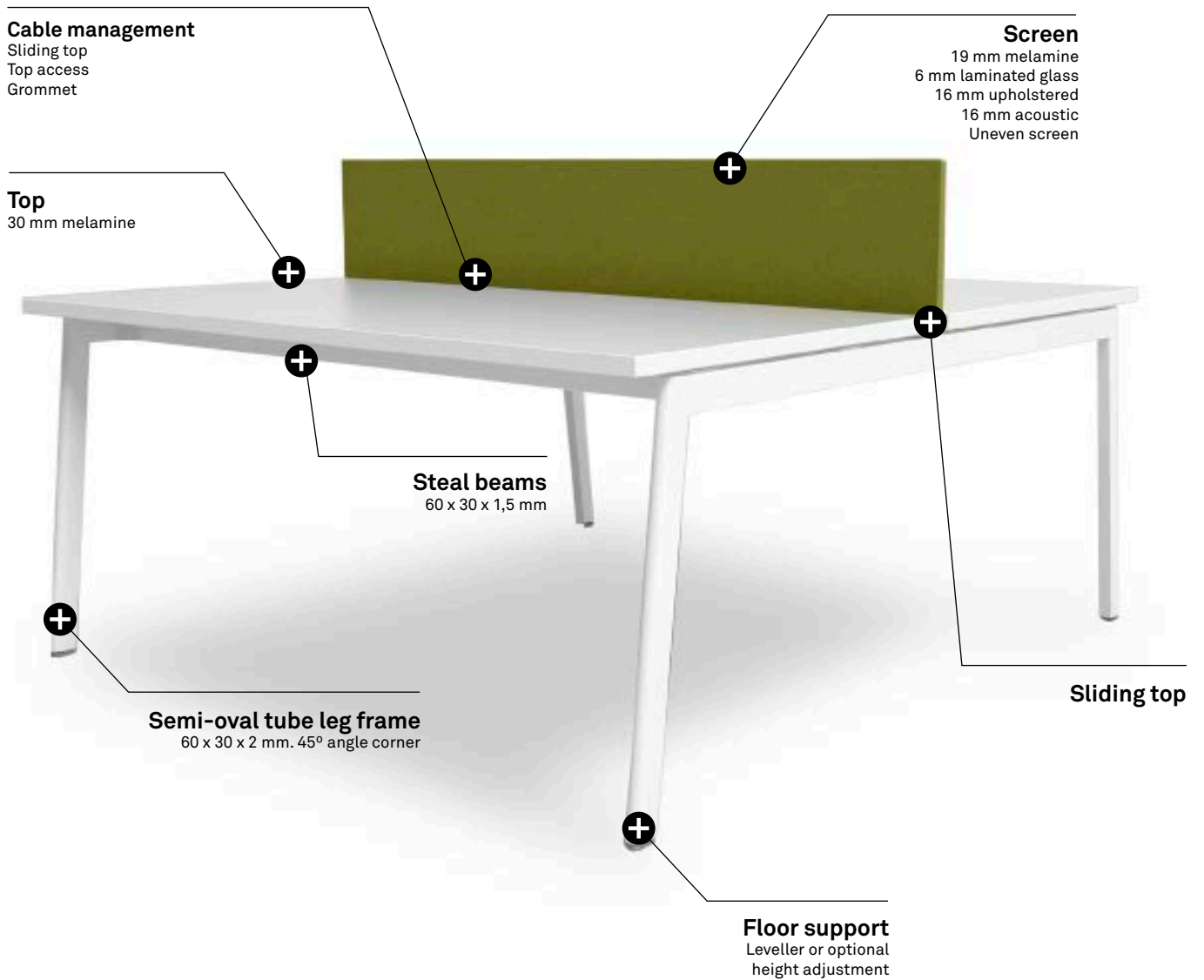

ELEMENT DESCRIPTION

BOARD

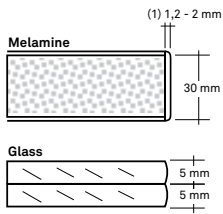

TOP

MELAMINE: 30 mm thick melamine particle board. 2 mm thick melamine particle board. 2 mm thick thermofused edges around the perimeter. Drilled underneath to allow a correct assembly. The quality requirements for the board are made according to the UNE-EN 312 legal terms, corresponding to P2 board. The average 30 mm thick board density is 610 kg/m³.

GLASS: 10 mm thick laminated black or white glass and an inner butyral sheet. Polished edges and rounded corners. Fixed to the structure by silicone suckers.



Melamine



Glass

LEGFRAME

60 x 30 x 2 mm thick semi-oval tube. 100 micron layer epoxy paint. Legs meet crossbar. 60 x 30 x 1,5 mm beam as desk top support. The leg frame has a trestle shape. Polypropylene levellers. This program includes three types of leg frames: simple (for single desks), double (for bench desks) and add-on leg frames (for bench desks). The last type provides longitudinal growth for add-on desks and, as it is shorter than the bench side where it is installed, it facilitates the distribution of workstations.

Optional leg frame with height adjustment for single desks. 650 - 850 mm in 60 x 30 x 2 mm semi-oval tube with a 100 micron layer epoxy paint.



Legframe

HEIGHT ADJUSTMENT

LEVELLER: floor support with levellers to keep the desk surface straight (2cm).

LEG FRAME WITH HEIGHT ADJUSTMENT: (650-850 mm) with 60 x 30 x 2 mm semioval tube, with a 80-100 micron layer epoxy paint. Legs meet crossbar with a miter. Leg shapes as trestle. 2 polypropylene ends help keep the desk straight on irregular surfaces. It is available for single desk with legframe supports.



Levellers



Height adjustment

MODESTY PANEL

MELAMINE: 19 mm thick melamine particle board with 1.2 mm thick thermofused edges around the perimeter, fixed to the structure by specific fittings hidden below the desk.

METAL: 1.5 mm thick textured steel sheet panel with epoxy paint finish, polymerized at 220°C. The assembly system includes fittings to facilitate it all. It hangs from the front beam.



Melamine



Metal

ELEMENT DESCRIPTION

SCREEN

MELAMINE: 19 mm thick particle board with 1.2 mm thermofused edges around the perimeter. Fixed to the structure with specific fittings hidden below the desk.



Melamine

GLASS: 6 mm (3+3 mm) laminated glass with inner butyral sheet. Polished edges and rounded corners.



Glass

Fixed to the structure by specific fittings hidden below the desk.

UPHOLSTERED: 16 mm thick particle board base with both sides upholstered. Sewings at laterals. Share fittings with the rest of the screens.



Upholstered

UPHOLSTERED ACOUSTIC: 16 mm thick particleboard base covered with a 5 mm thick foam cover with 30Kg/m³ density and upholstered on both sides. Double perimeter seam. Fixing to the structure of the desk by specific fittings.



Acoustic

UNEVEN DESK SCREEN: a 3 mm steel sheet beam with an inverted "V" shape that supports 4 different parts, whose dimensions are: 30 x 381 mm, 480 x 381 mm, 730 x 281 mm and 480 x 281 mm. 2 nishes options: 5 mm thick ber board and 20 kg/m³ high density foam with 5 mm thick on each side of the part, later upholstered with Forma 5 fabrics; or 10 mm thick ber board with melamine cover. The screen parts have 280 mm height and 170 mm over the desk and are placed in triangle exchanging heights and colours.



Uneven

CABLE MANAGEMENT



SQUARE DESK GROMMETS

ABS tap of 94 x 94 mm and polished finish. Polypropylene piece Ø 80 mm inner. Height 25 mm (2 mm over top).



ALUMINIUM TOP ACCESS

Aluminium part overall dimensions 367 x 127 x 33 mm. Extruded tap aluminium 348 x 89 mm and 4 mm average thickness. Aluminium injection inner piece average thickness 2.5 mm.



SLIDING TOP KIT

Set of five plastic POM and polyamide pieces that allows slide the desk top over the structure to access to the electrification located under the desk top. Ordering 1 sliding top kit for single desk, 2 kits for bench desk, one for each desk top.



POLYAMIDE TOP ACCESS

Polyamide part outer dimensions are 245 mm x 125 mm x h: 25 mm. The inner has a gap of 225mm x 90mm for the cable management. Set of two pieces made of polyamide with 10% glass fiber and 20% microspheres.

HORIZONTAL CABLE DRIVING



METAL TRANSVERSALE CABLE TRAY

1,5 mm thick blank folded sheet tray. Dimensions 463 x 136 x 124 mm. Folds for fixing between beams.



POLYPROPYLENE CABLE TRAY

Variable thick polypropylene tray. Overall dimensions 365 x 165 x 150 mm. Fixation to top directly by screws.



REMOVABLE METAL TRANSVERSALE CABLE

1,2 mm thick folded sheet metal tray, with final piece and fastening polyamide clamp to beam. Sheet dimensions: 920/720 x 121.9 x 98.3 mm. Overall dimensions: 1000/800 x 195.4 x 133.4 mm.



METAL CABLE TRAY TO SERVICE POWER

Metal cable tray to service power outlet, made of steel sheet, 1,2 mm thickness and 300 mm in length. Possibility of setting a power block. Fixing in the desk top with wooden screws. outlet

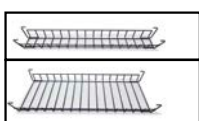

REMOVABLE WIRE CABLE TRAYS

Electrowelded wire tray Ø 5 mm rod. Fix to the tap by metal plates.

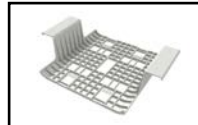

REMOVABLE METAL DOUBLE CABLE TRAY

1,2 mm thick folded sheet tray. Dimensions 1200/1000 x 338 mm. Polyamide pieces for subjection to beam. Overall dimensions of the set: 1200/1000 x 489.3 x 142.5 mm.

POLYPROPYLENE WIRE CABLE TRAY

Variable thick polypropylene tray. Overall dimensions 472 x 360 x 114 mm. Fixation to beams by folds in the mold. It is possible to screw it to the top.

ELEMENT DESCRIPTION

ACCESSORIES FOR DESK SURFACE

VERTICAL CABLE DRIVING



METAL CABLE PILLAR

1,5 mm thick metal pillar. Section 71 x 70 mm, base 160 x 160 mm. Overall height 572.5 mm.



CABLE SPINE FOR ELECTRIFICATION

Spiral thermoplastic material, anchored to the top by screws and to the ground with a pedestal base. Silver gray finish.



SINGLE CABLE MANAGEMENT FROM THE LEG FRAME

1 mm thick folded sheet metal column in "C" shape. 31,5 x 38,2 mm and 584 mm height. Fixation to leg by pressure.

ADDITIONAL ACCESSORIES



ADJUSTABLE CPU CABINET

Support folded metal sheet, 2 mm thick. Adjustable height and width to suit different dimensions. Screwed to desk top. Flexible polyurethane protections to prevent vibration and to ensure an optimal fit.



4 WAY POWER BLOCK

16A 250V sockets with 3 x 1.5 mm² power cable. CAT5E network cable.



3 WAY POWER BLOCK WITH 2X RJ45 DATA

16A 250V sockets with 3 x 1.5 mm² power cable. CAT5E network cable.



POWER CABLE AND EXTENSION CABLE

3 x 1,5 mm² cable 250V 16A with grounding.

CONFIGURATIONS AND DIMENSIONS

DESKS AND RETURN DESKS

	DESK	A x B	200 x 90 180 x 90 180 x 80 166 x 80	160 x 80 140 x 80 120 x 80
	DESK WITH A 43 MM SUPPORT PEDESTAL	A x B	180 x 80 160 x 80 140 x 80	
	DESK WITH A 43 MM HIGH DESK PEDESTAL	A x B	180 x 80 160 x 80 140 x 80 120 x 80	
	RETURN DESKS	A x B	100 x 56 80 x 56 80 depth desk 95 x 56 90 depth desk	

h: 74 cm

ADD-ON DESKS FROM A LEGFRAME

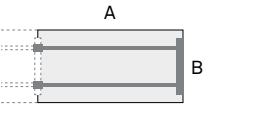
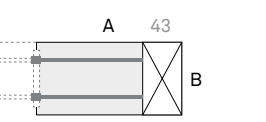
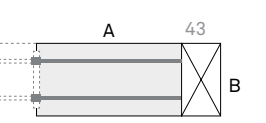
	DESK	A x B	180 x 80 160 x 80 140 x 80 120 x 80
	DESK WITH A 43 MM SUPPORT PEDESTAL	A x B	180 x 80 160 x 80 140 x 80
	DESK WITH A 43 MM DESK HIGH PEDESTALS	A x B	180 x 80 160 x 80 140 x 80 120 x 80

h: 74 cm

ADD-ON DESKS FROM PEDESTALS

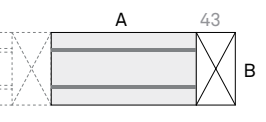
	DESK	A x B	180 x 80 160 x 80 140 x 80 120 x 80
	DESK WITH A 43 MM SUPPORT PEDESTAL	A x B	180 x 80 160 x 80 140 x 80
	DESK WITH A 43 MM DESK HIGH PEDESTAL	A x B	180 x 80 160 x 80 140 x 80 120 x 80

h: 74 cm

CONFIGURATIONS AND DIMENSIONS

GLASS OVERVIEWS

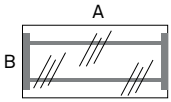
	DESK	$A \times B$	200 x 90 180 x 80 160 x 80
---	------	--------------	----------------------------------

h: 72 cm

BENCH DESKS 2 POSITIONS

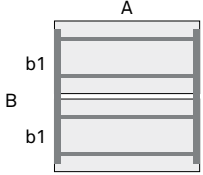
	BENCH DESK SUPPORTED BY A LEGFRAME	$A \times B/b1$	180 x 166/80 160 x 166/80 140 x 166/80 120 x 166/80
---	------------------------------------	-----------------	--

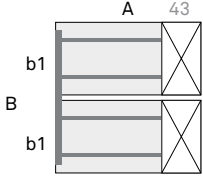
	BENCH DESK SUPPORTED BY A 43 MM WIDE PEDESTAL	$A \times B/b1$	180 x 166/80 160 x 166/80 140 x 166/80
---	---	-----------------	--

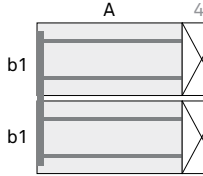
	BENCH DESK SUPPORTED BY A HIGH DESK PEDESTAL	$A \times B/b1$	180 x 166/80 160 x 166/80 140 x 166/80 120 x 166/80
---	--	-----------------	--

h: 74 cm

BENCHS DESKS 4 POSITIONS

	BENCH DESK SUPPORTED BY A LEG FRAME	$A/a1 \times B/b1$	360/180 x 166/80 320/160 x 166/80 280/140 x 166/80 240/120 x 166x80
---	-------------------------------------	--------------------	--

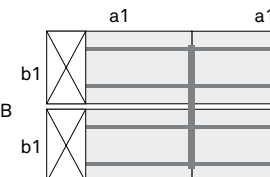
	BENCH DESK SUPPORTED BY A 43 MM WIDE PEDESTAL	$A/a1 \times B/b1$	360/180 x 166/80 320/160 x 166/80 280/140 x 166/80
---	---	--------------------	--

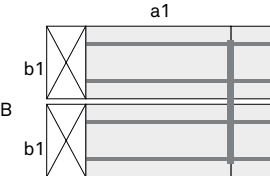
	BENCH DESK SUPPORTED BY A HIGH DESK PEDESTAL	$A/a1 \times B/b1$	360/180 x 166/80 320/160 x 166/80 280/140 x 166/80 240/120 x 166x80
---	--	--------------------	--

h: 74 cm

CONFIGURATIONS AND DIMENSIONS

BENCH DESKS AND ADD-ON DESKS

	<p>BENCH DESK SUPPORTED BY FRAMELEGS</p>	<p>$A \times B/b1$</p>	<p>180 x 166/80 160 x 166/80 140 x 166/80 120 x 166/80</p>
	<p>BENCH DESK SUPPORTED BY 43 MM PEDESTALS</p>	<p>$A \times B/b1$</p>	<p>180 x 166/80 160 x 166/80 140 x 166/80</p>
	<p>BENCH DESK SUPPORTED BY DESK HIGH PEDESTALS</p>	<p>$A \times B/b1$</p>	<p>180 x 166/80 160 x 166/80 140 x 166/80 120 x 166/80</p>

h: 74 cm

BENCH DESK LINKS

	<p>ENDING LINK</p>	<p>$A \times B$</p>	<p>45 x 166</p>
	<p>INNER LINK</p>	<p>$A/a1 \times B$</p>	<p>65/22 x 166</p>

h: 74 cm

CONFIGURATIONS AND DIMENSIONS

DESK SUPPORT WITH AXIS CABINETS

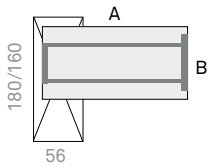
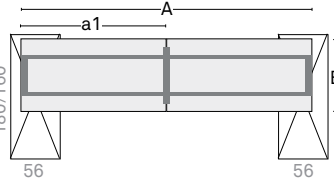
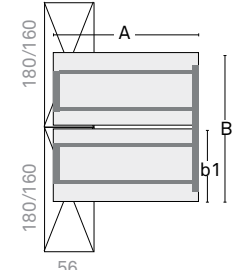
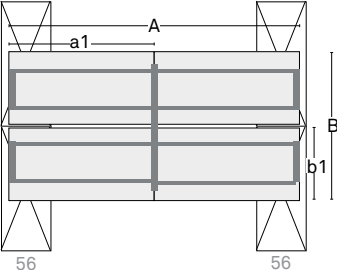
	<p>SINGLE DESK</p> <p>$A \times B$</p> <p>180 x 80 160 x 80 180 x 67 160 x 67</p>
	<p>DOUBLE DESK</p> <p>$A/a1 \times B$</p> <p>360/180 x 80 320/160 x 80</p>
	<p>BENCH DESK FOR 2</p> <p>$A \times B/b1$</p> <p>180 x 166/80 160 x 166/80 180 x 140/67 160 x 140/67</p>
	<p>BENCH DESK FOR 4</p> <p>$A/a1 \times B/b1$</p> <p>360/180 x 166/80 320/160 x 166/80</p>

h: 74 cm

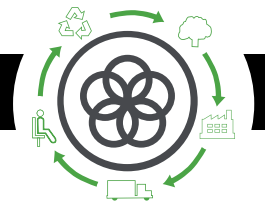

Life Cycle Analysis
M10 Program



RAW MATERIALS		
Raw Material	Kg	%
Steel	30,67 Kg	48%
Plastic	0,64 Kg	1%
Wood	32,6 Kg	59%

% Recycled material= 52%
 % Recyclable materials= 99%

Ecodesign

Results reached during the life cycle stages



MATERIALS

Wood
 70% of the wood material is recycled, has PEFC/FSC and complies within the E1 standard.

Steel
 15%-99% recycled material.

Plastic
 30%-40% recycled material.

Paintings
 Powder painting without COV emissions

Packings
 100% recyclable with inks with no solvents.

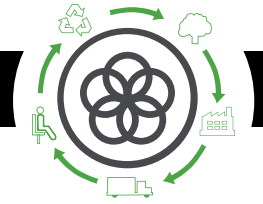

PRODUCTION

Raw materials use optimization

Board, upholstery and steel tubes cut.

Renewable energies use

reducing the CO2 emissions. (Photovoltaic pannels)

Energy saving measures

in all production process

COV global emission reduction

of the production processes by 70%.

Podwer painting

ecoverly of 93% of the non deposited painting

Glue removal from the upholstery

The facilities

have an internal sewage for liquid waste.

Green points

at the factory

100% waste recycling

at production process ans dangerous waste special treatment.



TRANSPORT

Cardboard use opmitization

of the packings

Cardboard and packing materials use reduction

Flat packings and small bulks

to optimize the space.

Solid waste compacter

which reduces transport and emissions.

Light volumes and weights

Transport fleet renewal

reducing by 28% the fuel consumption.

Suppliers area reduction

Local market power and less pollution at transport.



USE

Easy maintenance and cleaning

without solvents.

Forma 5 guarantee

The highest quality

for materials to provide a 10 year average life of the product.

Useful life optimization

of the product due to a standarized and modular design.

The boards

with no E1 particle emission.



END LIFE

Easy unpacking

for the recyclability or compound reuse.

Piece standarization

for the use.

Recycled materials used for products (% recyclability):

Wood is 100% recyclable.
Steel is 100% recyclable.

With no air or water pollution

while removing waste.

Returnable, recyclable and reusable packing

Product recyclability 99%

MAINTENANCE AND CLEANING GUIDE

MELAMINE PIECES

Rub the dirty spots with a wet cloth with PH neutral soap.

PLASTIC PIECES

Rub the dirty spots with a wet cloth with PH neutral soap.

METAL PIECES

- 1 Rub the dirty spots with a wet cloth with PH neutral soap.
- 2 Polished aluminium pieces can have their polish bak by covering and rubbing them with a dry cotton cloth.

GLASS PIECES

Rub the dirty spots with a wet cloth with PH neutral soap.

Do not use abrasive products in any case.

LEGAL TERMS

CERTIFICADOS

Forma 5 certifies that M10 programme has passed tests conducted in the laboratory of internal Quality Control and TECNALIA Research Technology Center, obtaining "satisfactory" results in the following tests:

UNE EN 527-1-2001 norm. Office furniture. Desks. Part 1: Dimensions.

UNE EN 527-2-2003 norm. Office furniture. Desks. Part 2: Security mechanism requirements.

UNE EN 527-3-2003 norm. Office furniture. Desks. Part 3: Testing methods to determine the stability and mechanic resistance of the structure.

Developed by MARIO RUIZ