

m o o o i<sup>®</sup>



## Construction Lamp Suspended M

---

The industrial design of the Construction Lamp Suspended blends in nicely with its two elegant colour nuances and stylish brass details. Joost van Bleiswijk's signature electricity pole structure connects the lamp's shade to the ceiling, completing its look and feel with a touch of vintage Meccano.

---

<b>Designer</b>	Joost van Bleiswijk
<b>Year of design</b>	2016
<b>Material</b>	Die cast powdercoated aluminium, wooden version with wood slats.

# m o o o i<sup>®</sup>

## dimensions

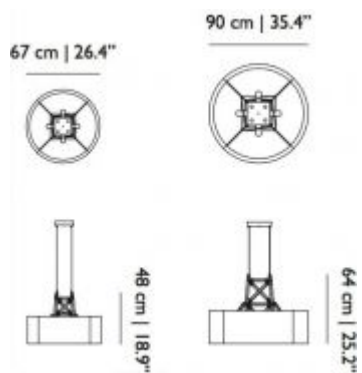

## packaging

H 58 cm | 22,8"

W 78 cm | 30,7"

D 78 cm | 30,7"

Colli 1/1

Product weight:

14 KG | 30,9 lb

With packaging:

15 KG | 33,1 lb

## Construction Suspended M Technical (ce)



**Material :**

Die cast powdercoated aluminium, wooden version with wood slats

**Colours:**

Matt black & matt white

**Outdoor:**

No

**Netto weight:**

15kg

**Input voltage:**

110-230V

**Power consumption:**

Max 40w

**Dimmable:**

Yes

**Lampholder:**

1 x E27

**Cable length:**

4 or 10m

**Cable colour:**

Black

**Canopy:**

Black or white