

Forma 5

Timber

Design by R&D Forma 5



Timber provides a system for both work and meeting tables that brings a warmth and friendliness to any space without sacrificing functionality or the ability to handle technology.

The structural integrity of the programme is born out by using a mixture of both steel beams and cross beams with solid natural beech legs. The product is both robust and stable. The finishes available are right on trend. The whole package is at the forefront of office environmental thinking.

Timber propone un sistema de mesas de trabajo y reuniones buscando una oficina sostenible con espacios amables, cálidos y funcionales.

El eje del programa se centra en un soporte mixto formado por una estructura de acero engarzada a patas de madera maciza de haya que aportan una gran robustez. Además, las tapas de mesa utilizan materiales de alta resistencia y acabados de tendencia, que consiguen un conjunto extremadamente atractivo.

Des espaces de travail plus naturels, respectueux de l'environnement et chaleureux à la fois que fonctionnels ? Timber est la réponse, en matière de postes de travail et de réunion.

La structure de la collection est mixte avec de poutres en acier, qui s'entrelacent avec des piètements en bois massif de hêtre. Pour une stabilité et une résistance sans faille. Les plateaux qui viennent s'y greffer sont réalisés dans des matériaux de haute résistance et technologie, dans des finitions actuelles, pour un ensemble résolument contemporain et attrayant.

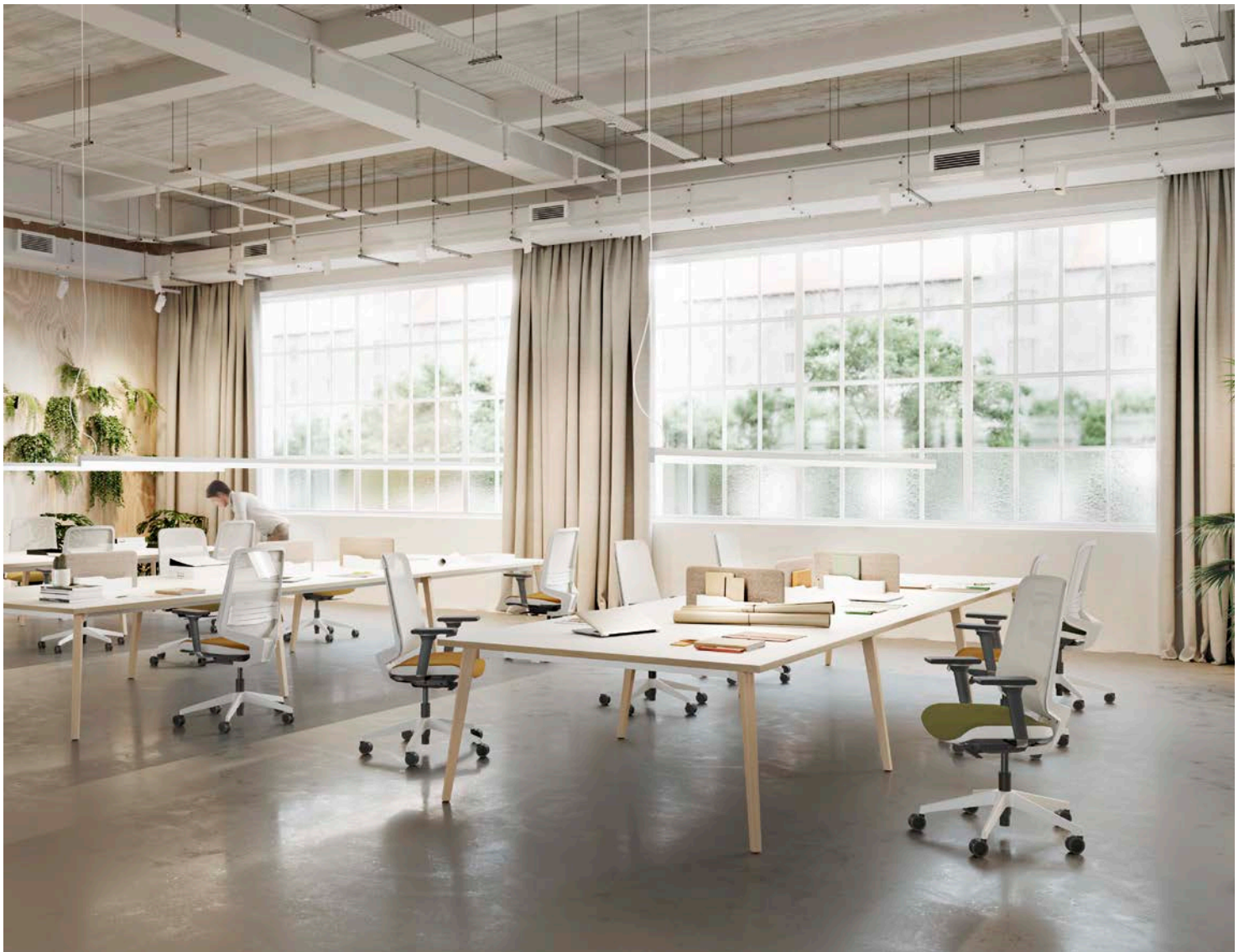

Organic design without sacrificing functionality
Diseño orgánico sin renunciar a la funcionalidad
Design organique et gage de fonctionnalité

Timber, with its natural wood leg frame, offers a more harmonious environment mirroring spaces you may find at home. This is perfect for 'multi user offices' where teamwork and creativity is important. These people benefit from the space and enjoy it. The structural system of Timber allows for unlimited growth. The product responds to the needs of the space and the functions of the people within it.

Timber propone con su pórtico de madera natural, un entorno más armónico que "hogariza" oficinas tipo Open Space y multiusuario donde el trabajo de equipo es importante. Además, su estructura permite el crecimiento ilimitado para crear sistemas de trabajo a medida según las necesidades de espacio y puestos.

Avec son piétement en bois naturel, Timber contribue à un environnement chaleureux qui rappelle « son chez soi » bien qu'utilisé dans l'aménagement en Open Space, où convivialité et travail en équipe sont de mise. Des modules de croissance permettent de multiplier et d'allonger les postes de travail.



The elegance that Timber portrays together with its natural nobility make this series ideal for executive offices.

La elegancia que transmite Timber junto con la nobleza y naturalidad de sus materiales hacen de esta serie una apuesta idónea para despachos ejecutivos.

Elégant car épuré grâce à des matériaux nobles et naturels, Timber convient parfaitement à un bureau de direction.



Oak edge: Available from the 2nd half of 2019
 Canto roble: disponible en 2º semestre 2019
 Chant chêne disponibles le deuxième semestre de 2019

If the space is illuminated correctly it shows off the natural finishes offered by Timber and increases the sense of comfort in the office, to reflect the home. It has been demonstrated that this type of environment favours the creatives. They are more likely to be motivated and enjoy the space.

Una correcta iluminación del espacio y los acabados naturales que ofrece Timber aumentan el bienestar y la sensación de confort en la oficina, que se hogariza. Está demostrado que este tipo de entornos favorece la creatividad de las personas que lo disfrutan.

Une illumination adéquate de l'espace allée aux finitions naturelles de Timber, augmentent les sensations de bien-être et de confort. L'espace de travail se rapproche ainsi de « chez soi ». Il a été démontré que ce type d'environnement favorise la créativité des personnes qui y évoluent.



Lacquered legs: Available from the 2nd half of 2019
 Lacado de las patas: disponible en 2º semestre 2019
 Piètements laqués disponibles le deuxième semestre de 2019

Current trends in office space tend to maximise the density within workareas whilst still providing large meeting rooms that are hardly used. So decorative solutions are now favoured to assist in this cooperation and exchange between these areas using natural and sustainable elements to increase the users well being.

Las tendencias actuales en mobiliario de oficina buscan optimizar el espacio en un contexto donde se estructuran zonas de trabajo en equipo más pequeñas antes que grandes salas de reunión que se utilizan en contadas ocasiones. Las soluciones decorativas que favorecen la cooperación y el intercambio pasan por elementos naturales y sostenibles que aumentan el bienestar del usuario.

Les tendances actuelles du mobilier de bureau cherchent à optimiser l'espace, dans un contexte où les zones de travail en équipe fragmentées sont privilégiées, au détriment de grandes salles de réunion souvent moins fréquentées. Les compléments de décoration appelés à favoriser coopération et échanges, visent tous à améliorer le bien-être de l'utilisateur par le biais de matériaux et de formes naturels.

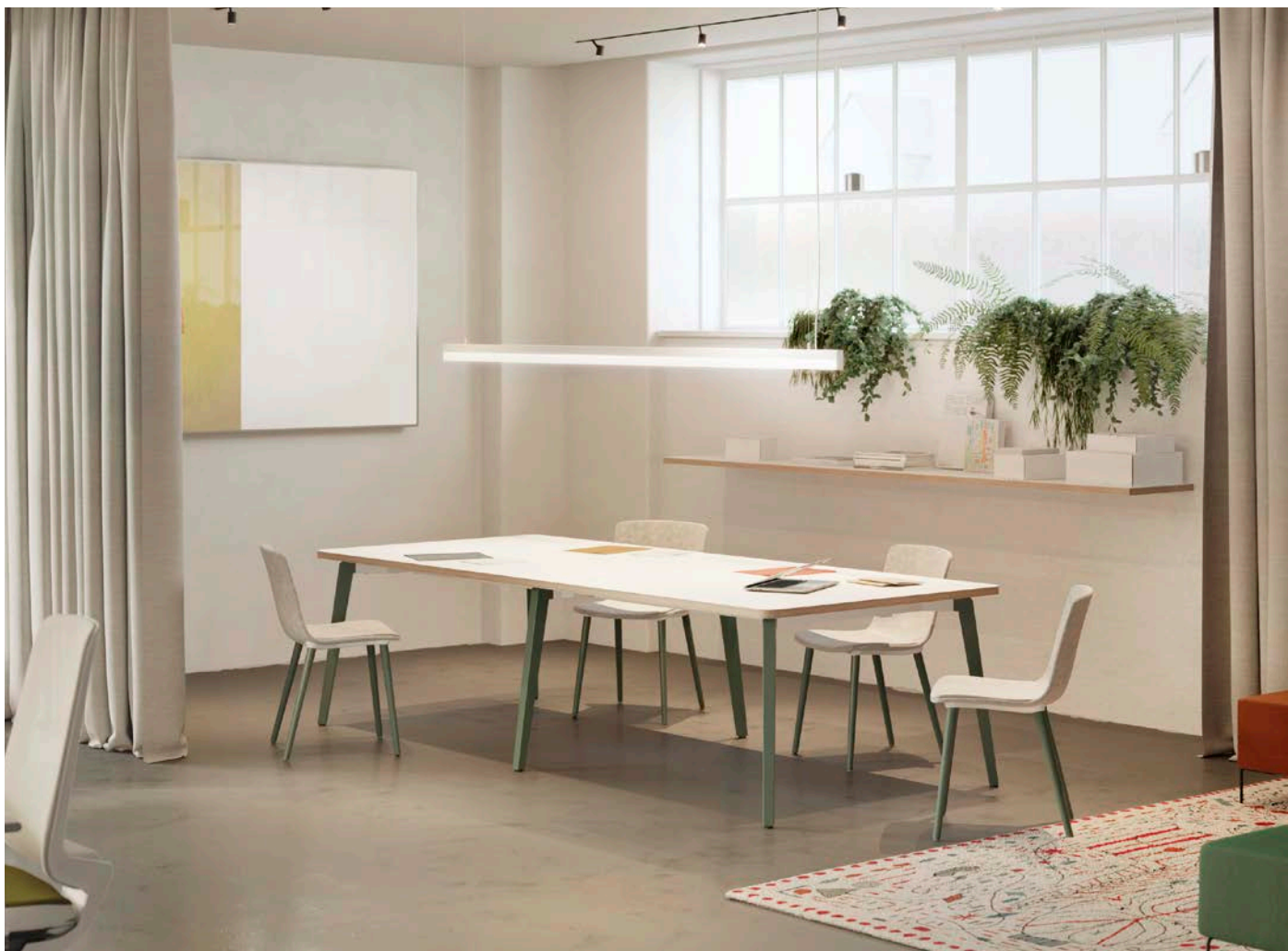

Lacquered legs: Available from the 2nd half of 2019

Lacado de las patas: disponible en 2º semestre 2019

Piètements laqués disponibles le deuxième semestre de 2019



From small collaborative work spaces to large meeting rooms, Timber brings its own organic essence, offering a wide range of shapes, finishes and structures that grow to meet your needs.

Desde pequeños espacios de trabajo colaborativo hasta grandes salas de juntas, Timber aporta su esencia orgánica a salas de reuniones, ofreciendo una gran gama de formas, acabados y estructuras que crecen para responder a cualquier necesidad.

Grâce à sa gamme de formes, de finitions et de structures, Timber apporte son essence organique aux espaces de réunion, qu'il s'agisse d'espaces collaboratifs de taille réduite, ou d'autres de réunion bien plus vastes.

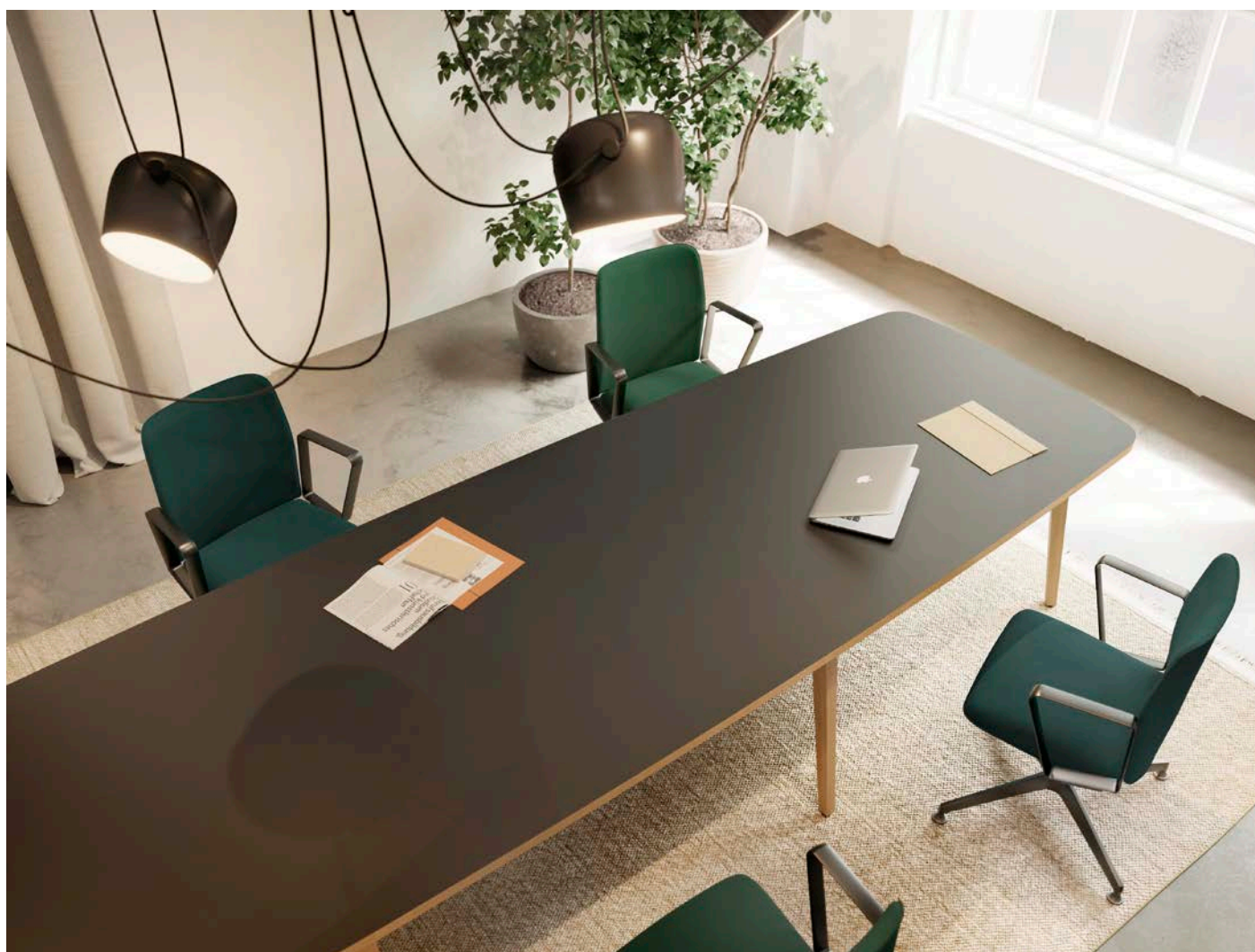



We are creating an open, comfortable and dynamic office where any space could utilise Timber to help eradicate the work versa hierarchical barriers that conventionally exist. We are searching for an ideal solution to provide a place purely for the benefit of users suited to their tasks.

Una oficina abierta, cómoda y dinámica donde cualquier espacio es idóneo e inspirador para trabajar y se eliminan barreras jerárquicas y convencionales en la búsqueda de un lugar adaptado a todos sus usuarios y tareas.

Un espace de travail ouvert, confortable et dynamique, propice à des échanges professionnels libres de contraintes hiérarchiques et conventionnelles, adapté à l'ensemble de ses utilisateurs et des diverses tâches dont ils s'acquittent.





Timber's commitment to organic design is clear, by using sustainable construction material that is 100% recyclable.

On the other hand the choice of the materials used have been selected to provide functionality. The meeting tables can be ordered in Fenix board, which is manufactured using efficient nanotechnology. This surface can have scratches thermally repaired. The surface is also resistant to unsightly fingerprints.

La apuesta de Timber por el diseño orgánico es patente ya que para su construcción se utilizan materiales sostenibles 100% reciclables.

Por otra parte, la elección de estos materiales se ha realizado teniendo en cuenta su funcionalidad. Así, las mesas de reunión pueden solicitarse en tablero Fénix, que se fabrica con nanotecnología eficiente que aporta una superficie muy resistente a los arañazos que se reparan térmicamente y un acabado anti-huella digital.

Le design organique de Timber est indiscutable, les matières premières intervenant dans sa construction étant 100 % recyclables. Leur fonctionnalité a été l'un des facteurs décisifs de leur choix. Par exemple, les dessus de tables de réunion sont également disponibles en Fenix, matériau issu de la nanotechnologie : particulièrement résistant aux rayures - même si ces dernières peuvent être réparées par une source thermique - et dont la surface est anti-empreintes.



Range / Modelos / Modèles

Single desks / Mesas singulares / Postes individuels



- Single desk
- Mesa individual
- Bureau individuel



- Single desk + return desk
- Mesa individual + ala auxiliar
- Bureau individuel

Round tables / Mesas redondas / Tables rondes



- Round table ø80
- Mesa "convivial" ø80
- Table de convivialité diamètre 80 cm



- Meeting table ø120
- Mesa de reunión ø120
- Table de réunion diamètre 120 cm

Raised tables / Mesas altas / Tables hautes



- Tables 110 cm high
- Mesa altura 110 cm
- Table H110 cm

Bench



- Bench 2 positions
- Bench 2 puestos
- Bench de 2



- Bench 4 positions
- Bench 4 puestos
- Bench de 4



- Unlimited add-on
- Crecimiento ilimitado
- Module de croissance

Task meeting tables / Mesas de reunión operativas / Tables de réunion opératives



- Rectangular table
- Mesa rectangular
- Table rectangulaire



- Rectangular table with 2 leaves
- Mesa rectangular 2 tapas
- Table rectangulaire à 2 plateaux



- Unlimited add-on
- Crecimiento ilimitado
- Module de croissance

Executive meeting table / Mesas de reunión dirección / Tables de réunion de direction



- Barrel table
- Mesa barril
- Table tonneau



- Rectangular table
- Mesa rectangular
- Table rectangulaire



- Tables with 3 tops or add-on
- Mesas 3 tapas o de crecimiento
- Tables à 3 plateaux ou de croissance illimitée

Desk tops / Tapas de mesa / Plateaux de table

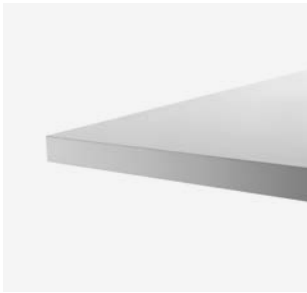

- Melamine in polar white with straight corners
- Melamina blanco polar esquinas rectas
- Mèlamine blanc polaire aux angles droits

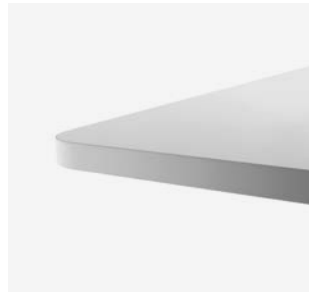

- Melamine in polar white with rounded corners
- Melamina blanco polar esquinas redondeadas
- Mèlamine blanc polaire aux angles arrondis

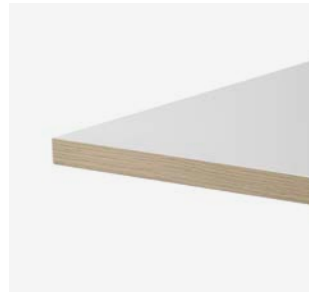

- Melamine in polar white with oak edge
- Melamina blanco polar cantos roble
- Mèlamine blanc polaire chant chêne



- Kompres in polar white and black edge finish
- Tapa Kompres blanco polar canto desnudo negro
- Plateau Kompres blanc polaire chant nu noir

2° second half 2019 / 2° semestre 2019 / Second semestre 2019



- Fenix white board with varnished laminated edge detail
- Tablero Fénix blanco, canto visto de tablero laminado barnizado
- Plateau Fénix blanc, chant apparent verni



- Fenix black board with varnished laminated edge detail
- Tablero Fénix negro, canto visto de tablero laminado barnizado
- Plateau Fénix noir, chant apparent verni

Desk accessories / Complementos de mesa / Compléments de bureau



- Melamine, glass, upholstered or upholstered acoustic screen
- Separador bilaminado, de vidrio, tapizado o acústico tapizado
- Écran mélaminé, en verre, tapissé ou acoustique tappissé



- Melamine or metal modesty panel
- Faldón bilaminado o metálico
- Voile de fond mélaminé ou métallique



- Aluminium top access
- Top access aluminio
- Top access en aluminium



- Polyamide top access
- Top access poliamida
- Top access en polyamide

Structure / Estructura / Structure



- Legs are made of solid varnished beech
- Patas madera maciza de haya
- Pieds en bois massif de hêtre



- Legs are made of solid varnished oak
- Patas madera maciza de roble
- Pieds en bois massif de chêne



- Legs are made of solid lacquered wood
- Patas madera maciza lacada
- Pieds en bois massif laqué

2^o second half 2019 / 2^o semestre 2019 / Second semestre 2019



- Levellers
- Niveladores
- Vérins de réglage



- Steel crossbar for the high table
- Travesaño para mesa alta de acero
- Traverse en acier pour table haute



- Steel beam and settings in white or matt black
- Viga y herraje de acero blanco o negro mate
- Poutre et quincaillerie en acier blanc ou noir mat

Meeting table cable management / Electrificación de reunión / Électrification de réunion



- Integrated cable management with tap and 3 sockets. Tilting and interchangeable tap
- Electrificación empotrable con tapeta de 3 tomas. Cubierta, basculante e intercambiable
- Boîtier 3 prises encastrable avec clapet



- Round vertical removable cable management with 4 sockets
- Electrificación extraíble vertical redonda de 4 tomas
- Prise de confort télescopique équipée de 4 prises



- Integrated power module on the surface with 3 sockets
- Regleta de electrificación empotrable en superficie con 3 tomas de corriente
- Nourrice encastrable équipée de 3 prises de courant



- Cable management with double opening and 8 sockets. Same finish as table top. Foulding tap in both directions
- Electrificación de doble apertura con 8 tomas. Embellecedor con recorte del propio tablero. Cubierta abatible en ambos sentidos
- Top Access avec possibilité de 8 prises. Cache dans la même finition que le ou les dessus. Clapet ouvrable sur ses deux longueurs

Overviews / Configuraciones y dimensiones / Configurations et dimensions

Desks and Bench desks / Mesas individuales y bench / Bureaux individuels et bench

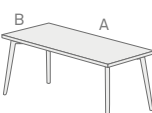
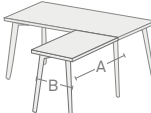
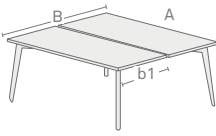
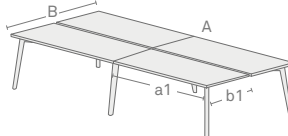
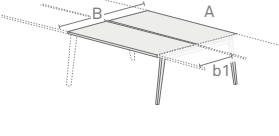
				
A x B 200 x 90 160 x 80 180 x 80 140 x 80	A x B 100 x 56	A x B/b1 180 x 160/78 140 x 160/78 160 x 160/78	A/a1 x B/b1 360/180 x 160/78 280/140 x 160/78 320/160 x 160/78	A x B/b1 180 x 160/78 140 x 160/78 160 x 160/78

Task meeting tables / Mesas de reunión operativas / Tables de réunion opératives

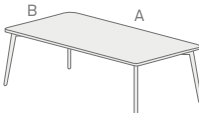
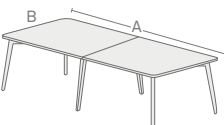
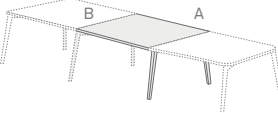
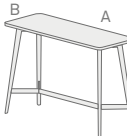
				
Ø 80 120	A x B 240 x 120 210 x 120	A x B 280 x 120	A x B 140 x 120	A x B 160 x 60 140 x 60

Executive meeting table / Mesas de reunión dirección / Tables de réunion de direction

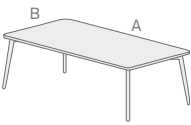
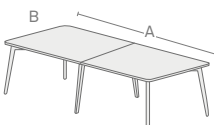
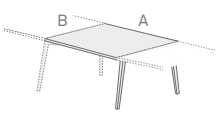
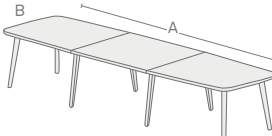
				
Ø 120	A x B 240 x 120 210 x 120	A x B 280 x 120	A x B 140 x 120	A x B 420 x 120

Designers / Diseñadores / Designers

Forma 5 R&D

Forma 5 Research and Development department is formed by ingenieurs, architects and designers. The staff is the key for innovating and evolving and the have helped develop successful chair and furniture programs. Another key factors are the accumulated experience and continuous industrial design training, new technologies and new materials.

El departamento Investigación y Desarrollo de Producto de Forma 5 está compuesto por un amplio equipo de ingenieros, arquitectos y diseñadores. Ellos son la pieza clave de la innovación y evolución de la cartera de productos de la compañía. Con ello, Forma 5 ha desarrollado lo más exitosos programas tanto de sillería como de mobiliario operativo y direccional, gracias a las tres décadas de experiencia acumulada y a la continua formación en diseño industrial, nuevas tecnologías y materiales.

Le département de Recherche et Développement de produit de Forma 5 est composé par un ample groupe d'ingénieurs, designers et architectes. Ils sont la clé pour l'innovation et le développement des produits de l'entreprise. Grâce à eux, Forma 5 présente une gamme très complète au niveau de sièges et du mobilier de bureau ainsi que de direction. Trois décennies d'expérience et une formation continue en design industriel, nouvelles technologies et la recherche de matériaux innovateurs.